



# Notice of Overall J/24 District 14 Racing

(Effective: March 1, 2024)

(Amendment #1: October 9, 2024)



## 1. Invitation

You are cordially invited to participate in J/24 one-design racing on USJCA District 14 as specified in this 2024 Notice of Overall J/24 District 14 Racing (“Notice of Overall Racing”), to be held from March through December 2024, and sponsored by the U.S. J/24 Class Association (“USJCA”) District 14 (“D14”), its local fleets and yacht clubs. J/24 District 14 racing as defined in this Notice of Overall Racing is administered by the USJCA District 14 Governor (“Governor”).

## 2. Getting Started

Competitors new to D14 Racing are welcome to visit our Getting Started page: <https://j24district14.com/getting-started/>

## 3. Eligibility

D14 Racing is open to all J/24 boats as defined by the International J/24 Class. All helmspersons must have purchased a Full Membership to the J/24 National or International Class and meet requirements for boat and crew as specified by this Notice of Overall Racing, and the associated “Notice of Circuit” or “Notice of D14 Series” shown below, in order to become participants in the “Circuit” or the “Series”.

## 4. Notices and Rules

The D14 competitive racing offerings are defined by the J/24 Texas Notice of Circuit (“Notice of Circuit”) and the J/24 District 14 Notice of D14 Series (“Notice of D14 Series”) containing its respective rules. More information may be found at each link below. The latest versions of all documents are posted on the D14 website (<https://j24district14.com/>).

- 2024 J/24 Texas Notice of Circuit:  
<https://j24district14.com/wp-content/uploads/2024-J24-Texas-Notice-of-Circuit-Rev-6.pdf>
- 2024 J/24 District 14 Notice of D14 Series (North Series, South Series, Super Series):  
<https://j24district14.com/wp-content/uploads/2024-District-14-Notice-of-D14-Series-Rev-5.pdf>

## 5. District 14 Registration and Fees

Yearly registration is required for participation on District 14 events, and is available online via the [Sailing Scores](https://www.sailingscores.com/event.php?event_id=229) website using the [2024 J24 D14 Yearly Registration Fees](https://www.sailingscores.com/event.php?event_id=229) event ([https://www.sailingscores.com/event.php?event\\_id=229](https://www.sailingscores.com/event.php?event_id=229)). This District 14 yearly registration requirement is in addition to the registration requirements for each individual regatta. Prior to registering for their first regatta, each helmsperson shall register his/her boat for one of the following options:

Option	Registration	Entitlement	Scoring	Fee
1	J/24 Texas Circuit	Scoring on J/24 Texas Circuit	7 Stops	\$45
2	Women’s TXCH	Scoring on the J/24 Texas Women’s Championship	Best 3	\$20
3	D14 Series	Scoring on the D14 North or South Series	Best 4	\$30
4	D14 Super Series	Scoring on the J/24 Texas Circuit, Women’s TXCH, D14 Series (North or South), and the D14 Super Series	Best 9	\$50
5	D14 Single Regatta	Scoring of a single D14 event, or Reservation of a Bow Number	Single Regatta	\$15

## 6. District 14 Racing Schedule

The 2024 D14 Racing Schedule is comprised of the following regattas:

	Location	Organizer	Event	Type <sup>(2,3,4)</sup>	Date
1	Heath, TX	<a href="#">Rush Creek Yacht Club</a>	Texas Independence Day	D14, TX Circuit	Mar 2-3
2	New Orleans, LA	<a href="#">New Orleans Yacht Club</a>	Mardi Gras Regatta	D14	Mar 16-17
3	Clear Lake Shores, TX	<a href="#">Galveston Bay Cruising Association</a>	Performance Cup	D14	Apr 13-14
4	Fort Worth, TX	<a href="#">Fort Worth Boat Club</a>	Cowtown Stampede	D14, TX Circuit	Apr 20-21
5	Grapevine, TX	<a href="#">Grapevine Sailing Club</a>	Mayor's Cup	D14	Apr 27-28
6	Shoreacres, TX	<a href="#">Houston Yacht Club</a>	Battleship Texas Regatta	D14	Apr 27-28
7	Rowlett, TX	<a href="#">Sapphire Bay Yacht Club</a>	Sisters With Sails Regatta	Women's TXCH	May 4
8	Oak Point, TX	<a href="#">Dallas Corinthian Yacht Club</a>	Corinthian Heritage Cup	D14, TX Circuit	May 17-19
9	Seabrook, TX	<a href="#">Lakewood Yacht Club</a>	Shoe Regatta	D14	May 18-19
10	Corpus Christi, TX	<a href="#">Corpus Christi Yacht Club</a>	Surfin' Safari	D14, TX Circuit	Jun 8-9
11	Shoreacres, TX	<a href="#">Houston Yacht Club</a>	Fairfax Moody Regatta	Women's TXCH	Jun 23
12	Oklahoma City, OK	<a href="#">Oklahoma City Boat Club</a>	One Design Regatta	Women's TXCH	Jul 13-14
13	Corpus Christi, TX	<a href="#">Corpus Christi Yacht Club</a>	Navy Regatta	D14	Aug 2-4
14	Dillon, CO	<a href="#">Dillon Yacht Club</a>	Dillon Open Regatta	D14	Aug 23-25
15	Grapevine, TX	<a href="#">Grapevine Sailing Club</a>	Girls Got Guts Regatta	Women's TXCH	Sep 7
16	Grapevine, TX	<a href="#">Grapevine Sailing Club</a>	Gold Rush	D14	Sep 14-15
17	Shoreacres, TX	<a href="#">Houston Yacht Club</a>	Houston Open One Design	D14, TX Circuit	Sep 21-22
18	Heath, TX	<a href="#">Rush Creek Yacht Club</a>	George Griffith Regatta	D14	Sep 28-29
19	Fort Worth, TX	<a href="#">Fort Worth Boat Club</a>	Ol' Man of the Sea	D14	Oct 12-13
20	Oak Point, TX	<a href="#">Dallas Corinthian Yacht Club</a>	Terlingua in Exile	D14	Oct 26-27
21	Seabrook, TX	<a href="#">Lakewood Yacht Club</a>	J/Fest Southwest <sup>(1)</sup>	D14, TX Circuit	Nov 2-3
22	Canyon Lake, TX	<a href="#">Lake Canyon Yacht Club</a>	Wurstfest II <sup>(5)</sup>	D14	Nov 9-10
23	Shoreacres, TX	<a href="#">Houston Yacht Club</a>	Turkey Day Regatta <sup>(6)</sup>	D14, TX Circuit	Nov 22-24

(1) LYC J/Fest Southwest Regatta will host the 2024 USJCA Southwest Regional Championship (Qualifier for the 2025 J/24 World Championship).

(2) Events in the J/24 Texas Circuit are labeled "TX Circuit".

(3) Events in the J/24 Texas Women's Championship are labeled "Women's TXCH".

(4) Events in the D14 North Series, South Series, and Super Series are labeled "D14".

**(5) Due to low water at Canyon Lake, the LCYC Wurstfest II Regatta will not constitute a part of the 2024 Texas Circuit.**

**(6) The HYC Turkey Day Regatta will be the 7th Circuit Stop of the 2024 Texas Circuit.**

## 7. Racing, Scoring, and Co-Helming

Racing formats, scoring, and Co-Helming requirements are defined within the respective Notice of Circuit (for the J/24 Texas Circuit) and the Notice of D14 Series (for the D14 North Series, South Series, and Super Series).

## 8. Measurement

In D14, Measurement is encouraged to help promote fairness amongst its competitors. Rules regarding measurement are identified in the respective Notice of Circuit and Notice of D14 Series. J/24 Class Measurers are listed on the class website at the following location: <http://j24usa.com/organization/measurement-committee/>

## 9. Bow Numbers

For scoring and identification of boats, unique bow numbers are required for participation in all D14 Racing (including the J/24 Texas Circuit and the D14 Series).

Bow numbers must be affixed to both external port and starboard sides of the forward bow area of each competing boat's hull. These numbers must be affixed as follows:

1. The leading edge of the forward number shall be approximately 12" aft of the stem.
2. The top edge of both numbers shall be approximately 6" from the rail.
3. All numbers must contrast with the color of the hull and be at least 12" in height.

Position Bow Numbers on your boat as shown in the figure below.

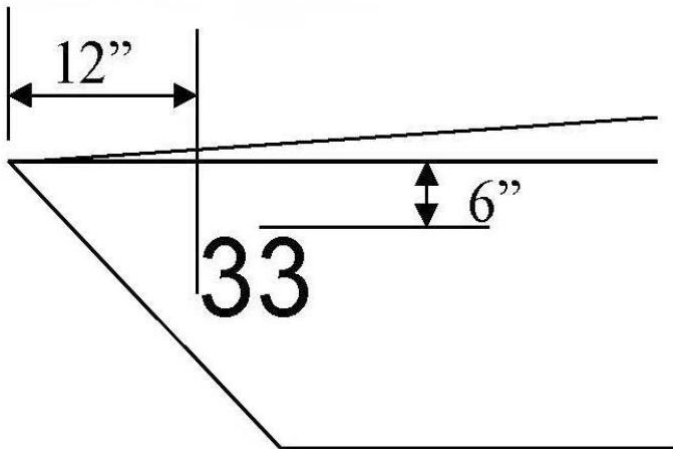

It is the responsibility of each participating boat to obtain and affix their bow numbers to their boat. Bow numbers will be assigned to each participating boat for the duration of the year. Bow numbers 01 through 10 are pre-assigned to the top ten (10) teams based on the previous year's standings on the J/24 Texas Circuit.

Bow numbers 11 through 99 are available for teams on a first come basis. Bow numbers 11 through 99 used in the previous year will be reserved for the boat that declared it in that previous year.

Available bow numbers can be reserved via the [Sailing Scores](#) website as set forth in **Section 5 District 14 Registration and Fees** (above). New competitors who are registering a bow number for the first time are encouraged to look at the previous year registration list (using the [2023 J24 D14 Yearly Registration Fees](#) event) to make sure the bow number they intend to register is not already reserved.

Bow numbers for the current year are considered declared once a boat has registered for a regatta using the declared Bow number. Issues relating to bow numbers (e.g. assignment, placement, size, etc.) will be resolved solely by the Governor.

## 10. J/24 Texas Women's Championship

For 2024 the J/24 Texas Women's Championship ("Women's TXCH") will consist of the best three (3) out of the following four (4) regattas:

	Location	Organizer	Event	Type	Date
1	Rowlett, TX	<a href="#">Sapphire Bay Yacht Club</a>	Sisters With Sails Regatta	Women's TXCH	May 4
2	Shoreacres, TX	<a href="#">Houston Yacht Club</a>	Fairfax Moody Regatta	Women's TXCH	Jun 23
3	Oklahoma City, OK	<a href="#">Oklahoma City Boat Club</a>	One Design Regatta	Women's TXCH	Jul 13-14
4	Grapevine, TX	<a href="#">Grapevine Sailing Club</a>	Girls Got Guts Regatta	Women's TXCH	Sep 7

In order to qualify for the J/24 Texas Women's Championship, boats shall be helmed by women, and each helmswoman must have purchased a Full Membership to the J/24 National or International Class. In addition, prior to registering for their first regatta, each helmswoman shall register her boat and pay the appropriate fee as described in **Section 5 District 14 Registration and Fees** (above).

All J/24 Class Rules shall apply to the regattas comprising the J/24 Texas Women's Championship except the following Class Rules which are waived: Measurement Certificate (Class Rule A.11.1 and Class Rule B.3.1), Inventory of Required and Optional Equipment (Class Rule B.3.2), Crew Limitations (Class Rule C.2.1), Sail Limitations (Class Rule C.10.2).

In addition, all boats and competitors must meet all requirements set forth in this Notice of Overall Racing, as well as individual regatta registration requirements in order to become participants in the J/24 Texas Women's Championship.

Deviations from these requirements may be granted by the Governor.

## 11. Prizes

J/24 Texas Circuit and D14 Series-specific awards are defined in their respective Notices. Additional D14 prizes will also be awarded to our D14-specific participants.

- **J/24 Texas Women's Champion** – (Perpetual Trophy) – Awarded to the winner of the J/24 Texas Women's Championship.
- **D14 North Series Champion** – (Perpetual Trophy) – Awarded to the winner of the D14 North Series.
- **D14 South Series Champion** – (Perpetual Trophy) – Awarded to the winner of the D14 South Series.
- **D14 Super Series Champion** – (Perpetual Trophy) – Awarded to the winner of the D14 Super Series.
- **J/24 Texas Circuit Champion** – (Perpetual Trophy) – Awarded to the winner of the J/24 Texas Circuit.
- **Road Warrior** – Awarded to those crewmembers that participated in all scheduled regattas of the J/24 Texas Circuit. See the J/24 Texas Notice of Circuit for more information.
- **Crew Most Valuable Player** – Awarded to a District 14 crew member that has gone above and beyond the call of duty to help make a team successful.
- **Rookie of the Year** – Awarded to a deserving new District 14 helmsperson.
- **Most Traveled/Competed** – (Perpetual Trophy) – Awarded to the District 14 team that has clearly shown their commitment to racing their J/24 in a traveling capacity.

## 12. Qualification for 2025 J/24 World Championship

See the J/24 Texas Notice of Circuit for allocation of berths for the 2025 J/24 World Championship.

### 13. J/24 Class Membership

All helmspersons must have purchased a Full Membership to the J/24 Class in order to participate in District 14 events. Full and Associate membership may be obtained online at <http://j24usa.com/membership/>

Crewmembers, other than helmspersons, are not required to be class members. However, they are encouraged to join in support of the USJCA by becoming Associate Members (\$35 per year).

### 14. US Sailing Membership and Discounts

Most of the regattas in District 14 will offer a discount on the entry fee with a US Sailing membership. Although not required, we encourage US Sailing membership. Individual membership (\$65 per year) may be obtained online at <https://www1.ussailing.org/mem/default.aspx>

### 15. Proof of Insurance

It has become a regular practice to require proof of insurance as a condition of entry to regattas. Each participating boat should be prepared to provide proof of valid third-party insurance with a minimum coverage of \$300,000 per incident or the amount as required by the regatta organizers.

Each boat owner should research insurance options. One such option is Gowrie Group who provides One Design focused insurance: <https://www.gowrie.com/USsailingPrograms/OneDesignProgram.aspx>

### 16. J/24 Class Rules

Certain J/24 Class Rules are outlined within the District 14 documents to highlight some pertinent rules. However, each person participating in District 14 racing is encouraged to review and learn the class rules. Current class rules may be accessed here: <http://www.j24class.org/rules-regulations/class-rules/>

### 17. Disclaimer of Liability

Competitors participate in these races entirely at their own risk. See RRS 3, Decision to Race. The organizing authority will not accept any liability for material damage, personal injury or death sustained in conjunction with or prior to, during, or after a race, series or regatta.

### 18. Additional Information

For more information regarding District 14 racing, please feel free to visit our website ([www.j24district14.com](http://www.j24district14.com)) or contact the Governor and/or one of the Circuit Representatives:

James Freedman:	USJCA District 14 Governor,	(214) 864-6024,	<a href="mailto:governor@j24district14.com">governor@j24district14.com</a>
Chris Holmes:	Circuit Rep (Dallas),	(940) 391-5565,	<a href="mailto:cholmes11803@yahoo.com">cholmes11803@yahoo.com</a>
Tim Johnson:	Circuit Rep (Houston),	(972) 832-5494,	<a href="mailto:graywolf-60@outlook.com">graywolf-60@outlook.com</a>
Brian Metz:	Circuit Rep (Austin),	(512) 964-4108,	<a href="mailto:b_metz67@msn.com">b_metz67@msn.com</a>
Mark Smith:	Circuit Rep (Fort Worth),	(469) 766-0277,	<a href="mailto:mark@verticaldatacom.com">mark@verticaldatacom.com</a>
Doug Weakly:	Circuit Rep (Corpus Christi),	(361) 815-3822,	<a href="mailto:doug.weakly@yahoo.com">doug.weakly@yahoo.com</a>



## Notice of Overall J/24 District 14 Racing

Amendment #1: October 9, 2024



The Notice of Overall J/24 District 14 Racing (Effective: March 1, 2024) is hereby amended as follows:

- Due to low water level at Canyon Lake, the Wurstfest II Regatta hosted by LCYC scheduled for November 9-10 will no longer constitute a part of the 2024 Texas Circuit.
- This regatta will be replaced by the Turkey Day Regatta hosted by HYC scheduled for November 22-24.

All the pertinent sections of this document have been amended as needed. Pertinent changes to the original text (Effective: March 1, 2024) are shown in bold red text.